

Equalizer Flange Spreading Tools



▼ SWi2025TI



SWi

FLANGE
SPREADING WEDGES

Spreading Force:
77,0 - 240,0 kN

Spreading Distance:
4,0 - 103,5 mm

Maximum Operating Pressure:
700 bar *

* Only relevant for hydraulic tools

- Practical, portable and lightweight
- Revolving handle to aid horizontal or vertical spreading
- Removable handle for improved access
- No finger pinch-point
- Increased step-depth on upper steps
- Safety lanyard – 1,0 m length
- Forged key components for strength and reliability
- Rapid disassembly and assembly
- Narrow jaw teeth – improved tool wear.



Caution

A minimum of two Flange Spreading Tools must be used when opening flange joints. This will enable the operator to maintain an equal spreading distance across the flange faces.

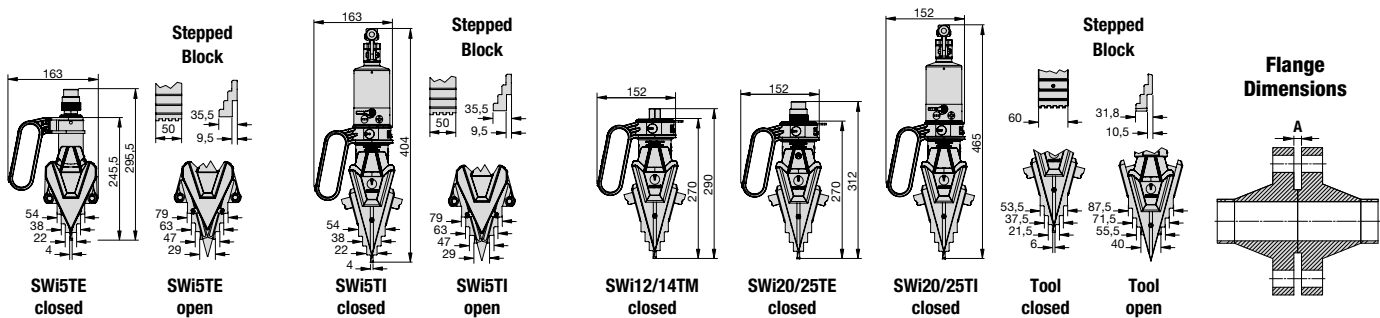

Model Number Tool Kit	Type	Maximum Spreading Force Per Tool (kN)	Spreading Distance Maximum * (mm)	Flange Dimensions Minimum Access Gap A (mm)	Jaw Width (mm)	Tool Weight (kg)	Kit Weight (kg)	Case Dimensions (mm)	Tool Number
SWi5TE-S	External Hydraulic	77,0	101,0	4,0	50,0	5,2	8,7	580 x 340 x 180	SWi5TE
SWi5TE-T	External Hydraulic	77,0	101,0	4,0	50,0	5,2	14,4	580 x 340 x 180	SWi5TE
SWi5TI-S	Integral Hydraulic	77,0	101,0	4,0	50,0	7,0	10,5	580 x 330 x 180	SWi5TI
SWi1214TMSTDSPB	Mechanical	140,0	103,5	6,0	60,0	6,2	13,0	580 x 330 x 165	SWi12/14TM
SWi2025TEMINSPB	External Hydraulic	240,0	103,5	6,0	60,0	6,4	11,6	580 x 330 x 165	SWi20/25TE
SWi2025TESTDSPB	External Hydraulic	240,0	103,5	6,0	60,0	6,4	20,7	920 x 500 x 205	SWi20/25TE
SWi2025TEMAXSPB	External Hydraulic	240,0	103,5	6,0	60,0	6,4	33,0	920 x 500 x 205	SWi20/25TE
SWi2025TISTDSPB	Integral Hydraulic	240,0	103,5	6,0	60,0	8,5	13,8	580 x 330 x 165	SWi20/25TI

* Using stepped blocks.

Equalizer Flange Spreading Tools

SWi5TE - Hydraulic Flange Spreading Wedge

SWi5TE-S - SWi5TE S Kit

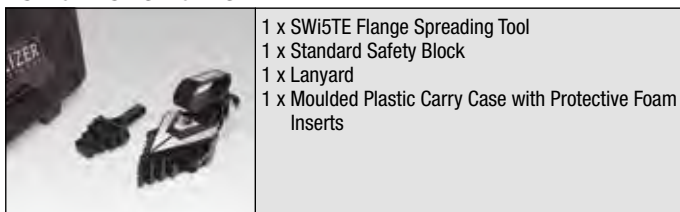

- 1 x SWi5TE Flange Spreading Tool
- 1 x Standard Safety Block
- 1 x Lanyard
- 1 x Moulded Plastic Carry Case with Protective Foam Inserts

SWi5TE-T - SWi5TE T Kit



- 2 x SWi5TE Flange Spreading Tools
- 2 x Standard Safety Blocks
- 2 x Lanyards
- 1 x Moulded Plastic Carry Case with Protective Foam Inserts

1640016-01 - SWi5TE Stepped Block Kit

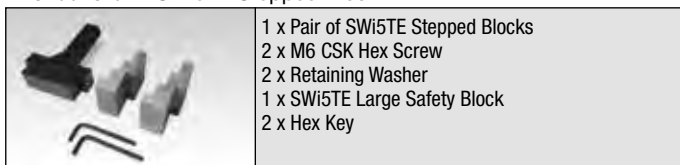

- 1 x Pair of SWi5TE Stepped Blocks
- 2 x M6 CSK Hex Screw
- 2 x Retaining Washer
- 1 x SWi5TE Large Safety Block
- 2 x Hex Key

SWi12/14TM - Mechanical Flange Spreading Wedge

SWi1214TMSTDSPB - SWi12/14TM STD Kit



- 1 x SWi12/14TM Flange Spreading Tool
- 1 x Torque Wrench with 22 mm Socket
- 1 x Set of Safety Blocks
- 1 x Pair of Stepped Blocks
- 1 x Lanyard
- 1 x Hex Key
- 1 x Moulded Plastic Carry Case

SWi20/25TE - Hydraulic Flange Spreading Wedge

SWi2025TEMINSPB - SWi20/25TE MIN Kit

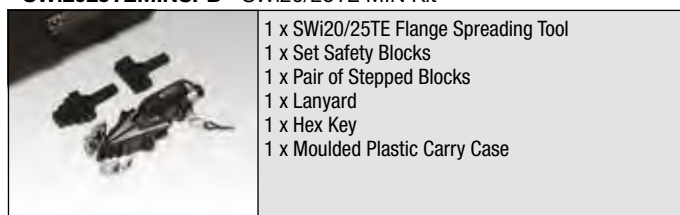

- 1 x SWi20/25TE Flange Spreading Tool
- 1 x Set Safety Blocks
- 1 x Pair of Stepped Blocks
- 1 x Lanyard
- 1 x Hex Key
- 1 x Moulded Plastic Carry Case

SWi2025TESTDSPB - SWi20/25TE STD Kit



- 1 x SWi20/25TE Flange Spreading Tool
- 1 x 700 bar Hydraulic Hose, 2 m with 90° Elbow
- 1 x 700 bar HP350S Single-Port Sealed Hand Pump with Gauge
- 1 x Set Safety Blocks
- 1 x Pair of Stepped Blocks
- 1 x Lanyard
- 1 x Hex Key
- 1 x Moulded Plastic Carry Case

SWi2025TEMAXSPB - SWi20/25TE MAX Kit



- 2 x SWi20/25TE Flange Spreading Tools
- 2 x 700 bar Hydraulic Hoses, 2 m with 90° Elbow
- 1 x 700 bar HP550D Twin-Port Sealed Hand Pump with Gauge
- 2 x Set Safety Blocks
- 2 x Pair of Stepped Blocks
- 2 x Lanyards
- 2 x Hex Keys
- 1 x Moulded Plastic Carry Case

SWi5TI - Integral Hydraulic Flange Spreading Wedge

SWi5TI-S - SWi5TI S Kit



- 1 x SWi5TI Flange Spreading Tool
- 1 x Standard Safety Block
- 1 x Lanyard
- 1 x Moulded Plastic Carry Case with Protective Foam Inserts

1640016-01 - SWi5TE Stepped Block Kit

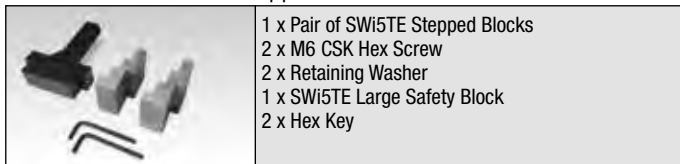

- 1 x Pair of SWi5TE Stepped Blocks
- 2 x M6 CSK Hex Screw
- 2 x Retaining Washer
- 1 x SWi5TE Large Safety Block
- 2 x Hex Key

SWi20/25TI - Integral Hydraulic Flange Spreading Wedge

SWi2025TISTDSPB - SWi20/25TI STD Kit



- 1 x SWi20/25TI Flange Spreading Tool
- 1 x Set of Safety Blocks
- 1 x Pair of Stepped Blocks
- 1 x Lanyard
- 1 x Hex Key
- 1 x Carry-Strap
- 1 x Moulded Plastic Carry Case

Equalizer Flange Spreading Tools



▼ SWi20/25TEEX



SWi



ATEX CERTIFIED FLANGE SPREADING WEDGES

Spreading Force:
140,0 - 240 kN

Spreading Distance:
6,0 - 103,5 mm

Maximum Operating Pressure:
700 bar *

* Only relevant for hydraulic tools

- ATEX certified
- Practical, portable and lightweight
- Revolving handle to aid horizontal or vertical spreading
- Removable handle for improved access
- No finger pinch-point
- Increased step-depth on upper steps
- Safety lanyard – 1,0 m length
- Forged key components for strength and reliability
- Rapid disassembly and assembly
- Narrow jaw teeth – improved tool wear.



Caution

A minimum of two Flange Spreading Tools must be used when opening flange joints. This will enable the operator to maintain an equal spreading distance across the flange faces.

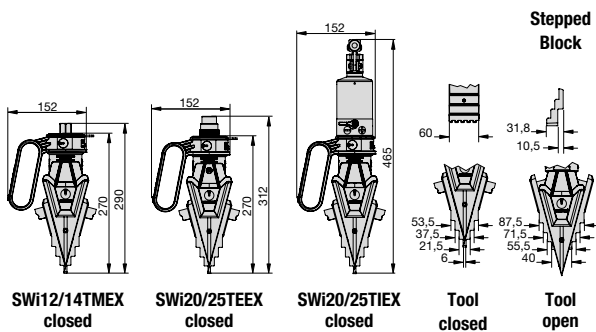

Flange Dimensions

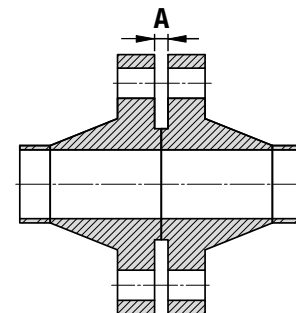

Model Number Tool Kit	Type	Maximum Spreading Force Per Tool (kN)	Spreading Distance Maximum * (mm)	Flange Dimensions Minimum Access Gap A (mm)	Jaw Width (mm)	Tool Weight (kg)	Kit Weight (kg)	Case Dimensions (mm)	Tool Number
SWi1214TMSTDEX	Mechanical	140,0	103,5	6,0	60,0	6,2	17,0	580 x 400 x 180	SWi12/14TMEX
SWi2025TEMINEX	External Hydraulic	240,0	103,5	6,0	60,0	6,4	15,0	580 x 400 x 180	SWi20/25TEEX
SWi2025TESTDEX	External Hydraulic	240,0	103,5	6,0	60,0	6,4	27,5	680 x 560 x 180	SWi20/25TEEX
SWi2025TEMAXEX	External Hydraulic	240,0	103,5	6,0	60,0	6,4	38,8	930 x 600 x 180	SWi20/25TEEX
SWi2025TISTDEX	Integral Hydraulic	240,0	103,5	6,0	60,0	8,5	17,5	580 x 400 x 180	SWi20/25TIEX

* Using stepped blocks.

Equalizer Flange Spreading Tools

SWi12/14TMEX - ATEX Certified Mechanical Flange Spreading Wedge



II 2G Ex h IIB T5 Gb
II 2D Ex h IIIC T85°C Db

SWi1214TMSTDEX - SWi12/14TMEX STD Kit



1 x SWi12/14TMEX Flange Spreading Tool
1 x ATEX Torque Wrench with 22 mm Socket
1 x Set of Safety Blocks
1 x Pair of Stepped Blocks
1 x Lanyard
1 x Hex Key
1 x Aluminium Carry Case with Protective Foam Inserts

SWi20/25TEEX - ATEX Certified Hydraulic Flange Spreading Wedge



II 2G Ex h IIB T5 Gb
II 2D Ex h IIIC T100°C Db

SWi2025TEMINEX - SWi20/25TEEX MIN Kit



1 x SWi20/25TEEX Flange Spreading Tool
1 x Set Safety Blocks
1 x Pair of Stepped Blocks
1 x Lanyard
1 x Hex Key
1 x Aluminium Carry Case with Protective Foam Inserts

SWi20/25TIEX - ATEX Certified Integral Hydraulic Flange Spreading Wedge



II 2G Ex h IIB T5 Gb
II 2D Ex h IIIC T100°C Db

SWi2025TISTDEX - SWi20/25TIEX STD Kit



1 x SWi20/25TIEX Flange Spreading Tool
1 x Set of Safety Blocks
1 x Pair of Stepped Blocks
1 x Lanyard
1 x Hex Key
1 x Carry-Strap
1 x Aluminium Carry Case with Protective Foam Inserts

SWi2025TESTDEX - SWi20/25TEEX STD Kit



1 x SWi20/25TEEX Flange Spreading Tool
1 x 700 bar ATEX Hydraulic Hose, 2 m with 90° Elbow
1 x 700 bar HP350S ATEX Single-Port Sealed Hand Pump with Gauge
1 x Set Safety Blocks
1 x Pair of Stepped Blocks
1 x Lanyard
1 x Hex Key
1 x Aluminium Carry Case with Protective Foam Inserts

SWi2025TEMAXEX - SWi20/25TEEX MAX Kit



2 x SWi20/25TEEX Flange Spreading Tools
2 x 700 bar ATEX Hydraulic Hose, 2 m with 90° Elbow
1 x 700 bar HP550D ATEX Twin-Port Sealed Hand Pump with Gauge
2 x Set Safety Blocks
2 x Pair of Stepped Blocks
2 x Lanyards
2 x Hex Keys
1 x Aluminium Carry Case with Protective Foam Inserts



These tools have been designed for use in potentially explosive atmospheres which is:

- Group II (Non-mining equipment)
- Equipment **category 2** where explosive atmosphere is likely to occur in normal operation
- Can be applied in **zones 1 and 2** of gaseous explosive atmospheres and in **zones 21 and 22** of dust explosive atmosphere
- **Gas G** or **Dust D** with type of protection **Ex h** for non-electrical equipment
- Suitable for use with **Group IIB** of a gases and vapours (Ethylene group) and **Group IIIC** of dust (conductive dust)
- For hydraulic tools **T5** means that minimum ignition temperature of gas or vapor **>100°C**; **T100°C** means that minimum ignition temperature of a dust cloud $\geq 150^{\circ}\text{C}$ and minimum ignition temperature of a 5mm dust layer $\geq 175^{\circ}\text{C}$
- For mechanical tools **T6** means that minimum ignition temperature of gas or vapor **>85°C**; **T85°C** means that minimum ignition temperature of a dust cloud $\geq 127,5^{\circ}\text{C}$ and minimum ignition temperature of a 5mm dust layer $\geq 160^{\circ}\text{C}$.

These tools have been designed and manufactured in accordance with the following transposed harmonized European standards:

- **EN ISO 80079-36:2016** Explosive atmospheres - Part 36: Non-electrical equipment for explosive atmospheres - Basic method and requirements;
- **EN ISO 80079-37:2016** Explosive atmospheres - Part 37: Non-electrical equipment for explosive atmospheres - Non-electrical type of protection constructional safety "c", control of ignition sources "b", liquid immersion "k":